

FACHL-xx-H LVDS-FFC 100 Ohm 10Gbit/sec High Speed for Hirose FH41/FH48 series

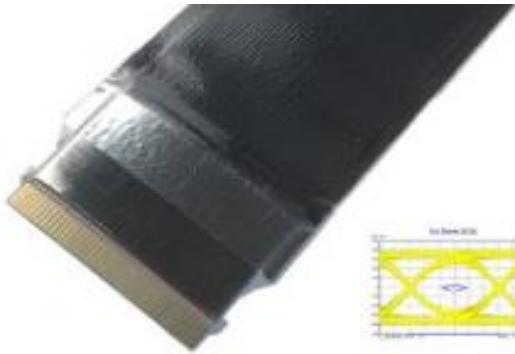

Features

compatible with Hirose FH41/FH48
Data rate up to 10Gbit/sec
Impedance 100Ω
One side LVDS foil
High flexibility and softness

Compatible Connector:

FH41-xxS-0.5SH horizontal with GND



FH48 –xxS-0.5SV vertical with GND



FACHL-xx-H LVDS-FFC 100 Ohm 10Gbit/sec High Speed for Hirose FH41/FH48 series

Dimensions:

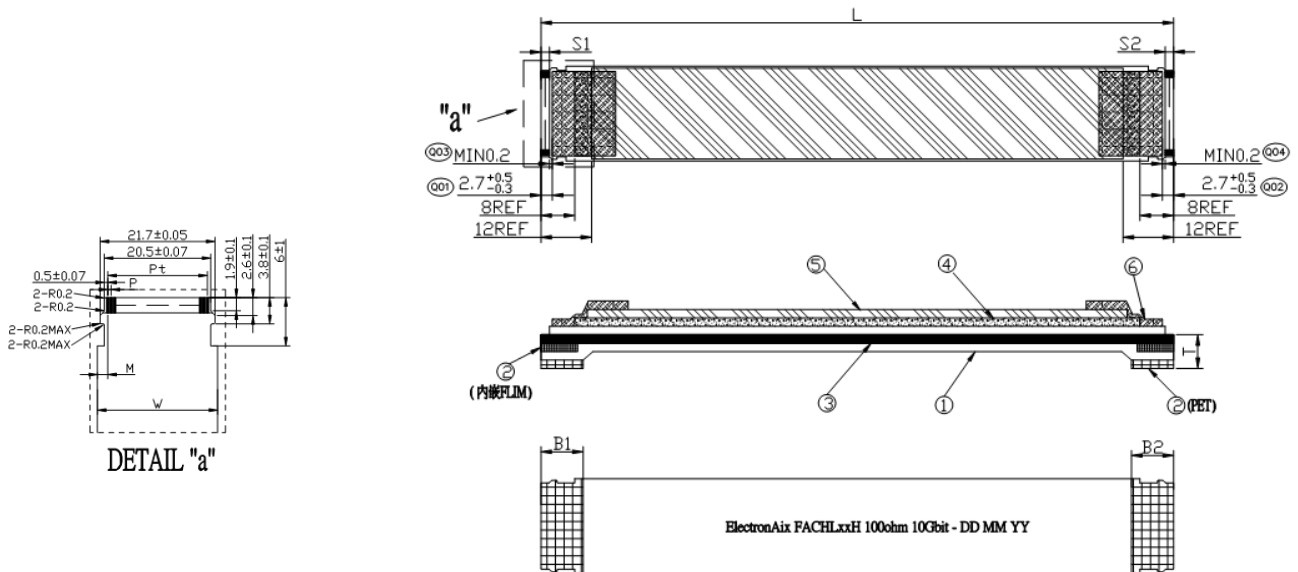

Pitch	P	0.5	±0.05 *
Total Pitch	Pt	(n-1)x0.5	±0.05*
Width	W	(N+5)x0.5	±0.07
Insert Thickness	T	0.3	±0.05
Strip length	S1	2.2	±0.5
	S2	2.2	±0.5
Reinforcement tape length	S3	10**	±2
	S4	10**	±2
Inner length	IL	TL-(S1+S2)	±2
Total length	TL	LLL	±2
No. of pins	N	NN	
Standard Conductor Dimension ***	Thickness 1	0.035	±0.005
	Width	0.3	±0.03
Slanting	A	< 0.3	

* Tolerance depending on connector spec. small tolerance is possible

** or customized length

*** Option see table below

FACHL-xx-H LVDS-FFC 100 Ohm 10Gbit/sec High Speed for Hirose FH41/FH48 series

Types:

A = SAME = Same Side



Print on this side: ElectronAix FACILxxH

B = OPP = Opposite Side



Print on one side: ElectronAix FACILxxH

Partnumber:

FACHL			P		-	22		23	GH
FACHL	T	NN	P	LLL	-	22	SS	23	GH
									<i>Gold Plating High Speed*</i>
									<i>Wire Dimension 0,035x0,3 (options see table) option</i>
									SS= Supporter Tape Length; 10mm/10mm = Standard
									<i>Strip Length in mm – no option</i>
									LLL= Total Length in mm
									<i>P=Positions</i>
									NN= No of Wires: 10 to 80
									T= Type: A= same Side / B= Opposite Side
<i>Product Series = FFC Aix Catcher Hirose FH41 / FH48 series LVDS</i>									

*High Speed - Data rate up to 10Gbit for lengths up to 150mm / 5Gbit for lengths up to 900mm

Wire options

P/N	Thickness	Width	Resistance (Ohm)	Rated Current
32	0,032	0,28	2.6Ω/m	0.3A
33	0,035	0,3	2.0Ω/m	0.3A
53	0,05	0,3	1.6Ω/m	0.4A

Contact us for customization.

- Double side LVDS Impedance 90Ohm or 100Ohm up to 17Gbit/sec
 - EMI Wrapped shield
 - EMI Laminated shield
 - Wire Dimension
 - Folding
 - Special print or labels
- FACHL-xx-HD
 - FACHE-xx
 - FACHE-xx-L

Environmental

The products meet EU RoHS Directive 2011/65/EU, including the delegated regulation (EU) 2015/863
The products meet EU REACH Directive 1907/2006/EU



FACHL-xx-H LVDS-FFC 100 Ohm 10Gbit/sec High Speed for Hirose FH41/FH48 series

Specification

1. Scope

For Laminated Flat Cable (Flat Conductor) With Reinforcing Tape

2. Applicable documents

The specification covers the construction and electrical properties of laminated flat cable (Flat Conductor) with reinforcing tape based on UL subject 757.

3. Material

3.1 Insulation: PET, White, T=0.06mm, UL20706 105°C 60V VW-1

3.2 P/ Tape: PET, T=0.225mm

3.3 Conductor: Cu, 0.28*0.032mm

3.4 Plating: Au (2µ" min)

4. Rating

4.1 Operating Voltage : 60V

4.2 Current Rating : 0.3A

4.3 Normal use Inserting: 5 cycles

4.4 Ambient Temperature Range: -40°C ~ +105°C

4.5 Warehouse Conditions: 25°C±15°C ; ≤60%RH

5. 6. Appearance

Reference 《FFC Inspection SOP

6 Tests

Item	Test Method	Specification
Conductor resistance	JIS C3102 at 20°C	See table
Insulation resistance	JIS-C3102	>100 MΩ
Dielectric withstanding voltage between conductors	AC250V 1min (0,5mm Pitch)	No Breakdown Current Leakage 1mA max
Flexing	180° bending	>20 Cycles
	U-Bending R5x50mm Stroke 60 cycles / min	>100.000 Cycles
Heat Resistance	+85°C 96hrs	Insulation and Dielectric withstanding Voltage pass
Cold Resistance	-40°C 96hrs	Insulation and Dielectric withstanding Voltage pass
High Temperature High Humidity	+60°C (90-95)%RH 96hrs	Insulation and Dielectric withstanding Voltage pass
Temperature Cycling	- 40°C 4hrs +25°C 2hrs +85°C 4hrs +25°C 2hrs	Insulation resistance and dielectric withstanding voltage pass
Salt Spray	+35°C 24hrs PH 6.5-7.2	before and after test, no corrosion and oxidation at contact area

FACHL-xx-H LVDS-FFC 100 Ohm 10Gbit/sec High Speed for Hirose FH41/FH48 series

7 Special Attention

- 7.1 Please hold supporting tape, then insert or pull out the FFC from a connector in a straight
- 7.2 When insert to connector, please avoid excessive force
- 7.3 After insert to connector, shall be not bended at Supporting-tape excessive, because Joiner is broken
- 7.4 For gold plated FFC, there is the Ni-plating, so please do not bend the FFC at the terminal part of Conductor. Otherwise a crack will be occurred at the plated part; after insert into the Connector, please also do not bend the FFC at the part of Supporting-tape, otherwise a crack will be occurred at the plated part.
- 7.5 Please avoid excessive force around supporting-tape
- 7.6 Please evaluate FFC properties in advance when use under particular condition (High temperature, High Humidity etc). There is possibility to be corrosion after 6 month
- 7.7 Please avoid the moving wiring at bending portion
- 7.8 Please estimate enough space when Joiner is used the moving wiring
- 7.9 When dropped to the floor, please clean Joiner's leads
- 7.10 Please don't touch the terminal part of the Conductor by hand, for it will cause discolored or rusted
- 7.11 Please don't use the sulfurous material together with the FFC to prevent short circuit between sulfurized conductors
- 7.12 Before Assembly: Expiry Date For One Year
After Assembly: Expiry Date For Fifteen Years